

REV	ECN	DESCRIPTION	DATE	MODIFIED
1		RELEASE	Mar-31-2025	
2	R09588	UPDATED LASER MARKING AND STRUCTURE	Oct-28-2025	

Amphenol PCD SZ
ORIGINAL
PDF Format
R&D

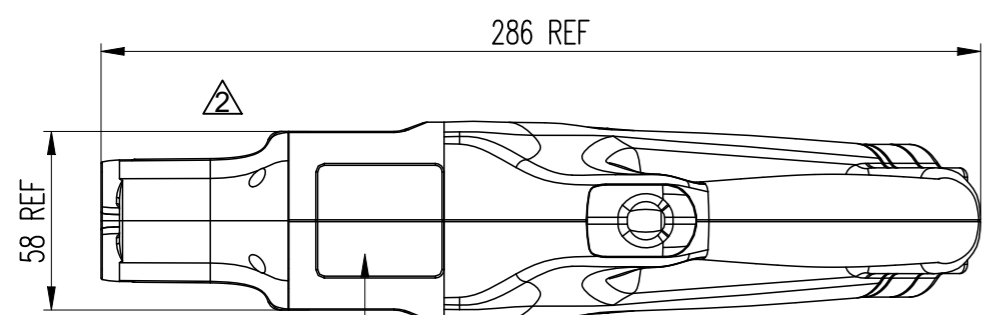
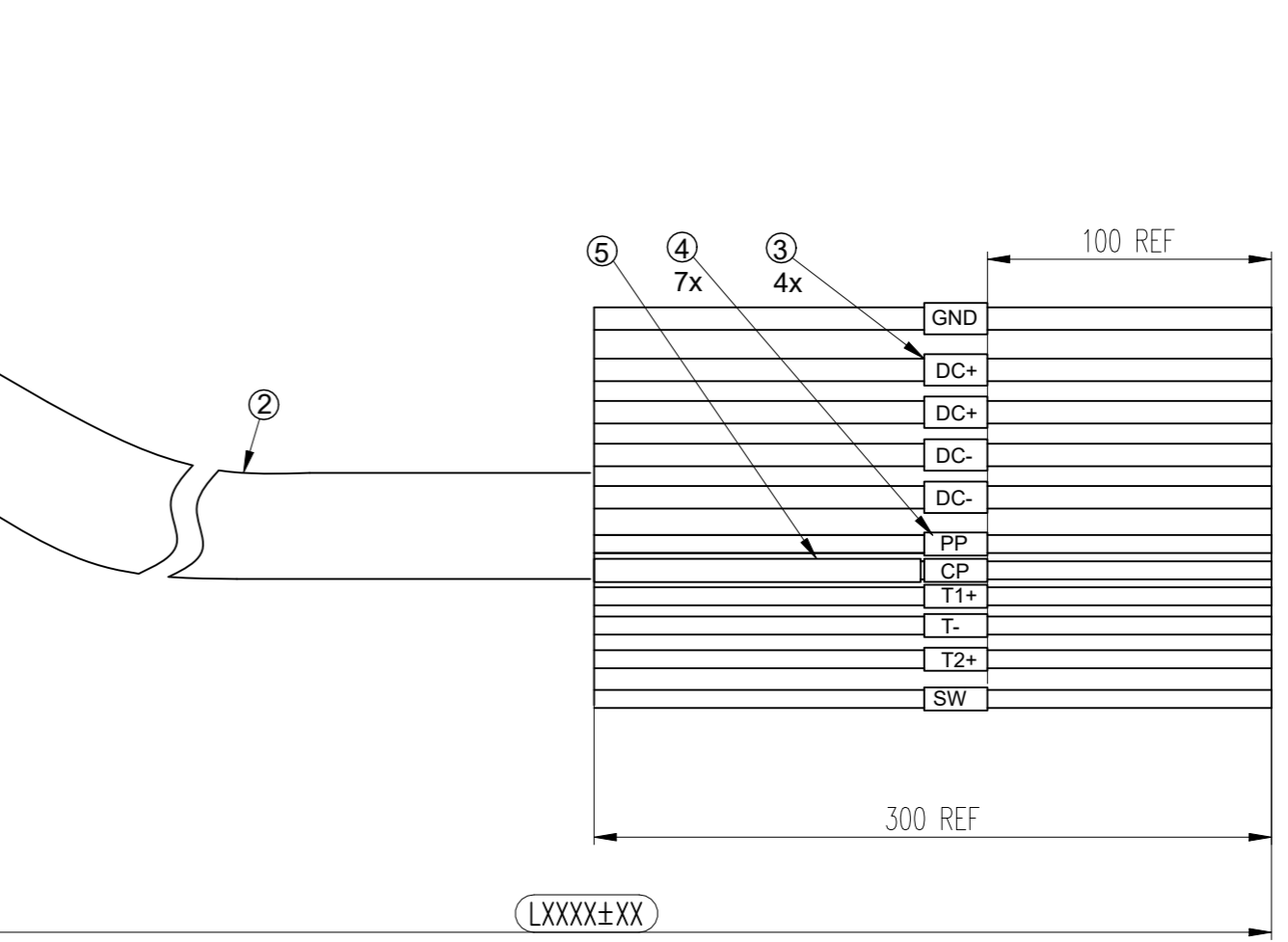
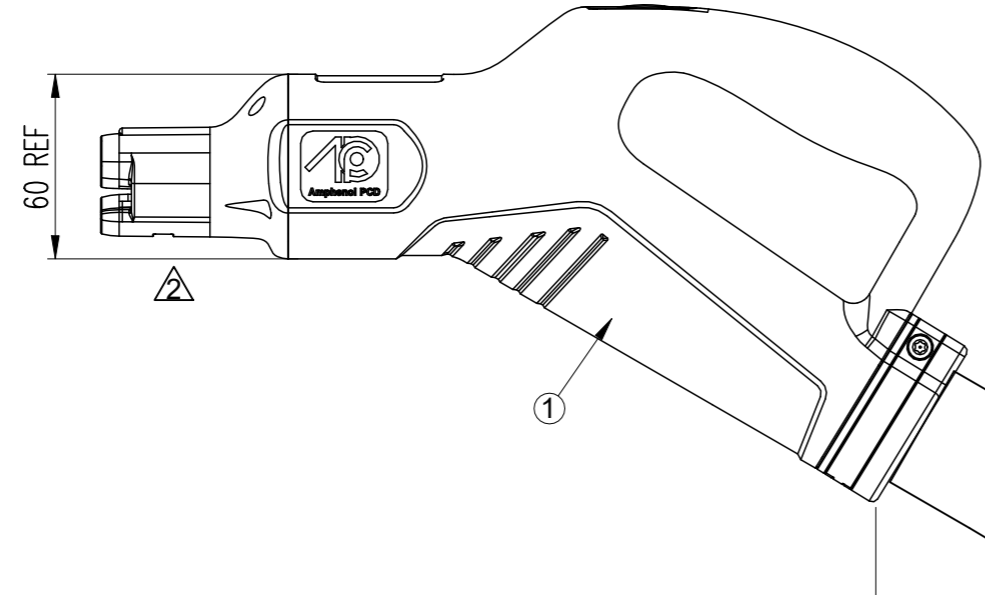
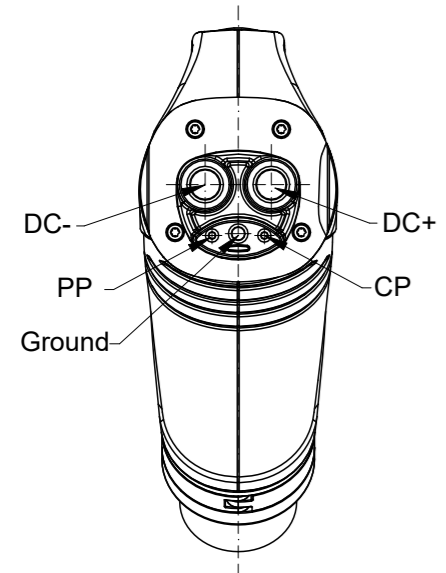

Total Length	Tolerance
0~1000mm	±50
1001~5000mm	±100
>5000mm	±200

TYPE: HVCON3MB250APLXXXX
T/N: XXXXXXXX YYWW
Rated: 250A, 1000Vdc
A&T: -40°C to +50°C

CAUTION: Not for current interrupting.
CAUTION: Do not use if there is any damage to the EV cable or the connector
IP-Class: Type 3S XX

Laser marking on plug

T/N:XXXXXXXX YYWW
Work order number + batch number+year+Week
Font: Arial

QR code Content including:
Part number
#Work order number
#Serial number ex:0001
(ex:HVCON3MB250APLXXXX#XXXXXXXX#XXXX)



CN:Made in China
MX:Made in Mexico

DIMENSIONS	TOLERANCES	PROJECTION	TITLE		
ANSI Y14.5M UNITS: MM CAD FILE	.X ± 0.50 .XX ± 0.05 ANGLES ± 2°		Amphenol PCD Shenzhen		
ORIGINAL	THIS DOCUMENT CONTAINS PROPRIETARY INFORMATION WHICH IS THE CONFIDENTIAL PROPERTY OF Amphenol PCD Shenzhen Co. Ltd Amphenol PCD Shenzhen Co. Ltd RESERVES THE RIGHT TO CLARIFY THIS DRAWING	ENGR	GEN3 NACS CONNECTOR 250A 1000V WITHOUT UHF F/R 4X3AWG CABLE ASSEMBLY		
		CHKD APPD	SIZE A3	DWG NO. C-HVCON3MB250APLXXXX	REV 2
		SCALE	1 :2	SHEET	1 OF 2

C-HVCON3MB250APLXXXX

C-HVCON3MB250APLXXXX

DC Mode of Connection
WITHOUT UHF

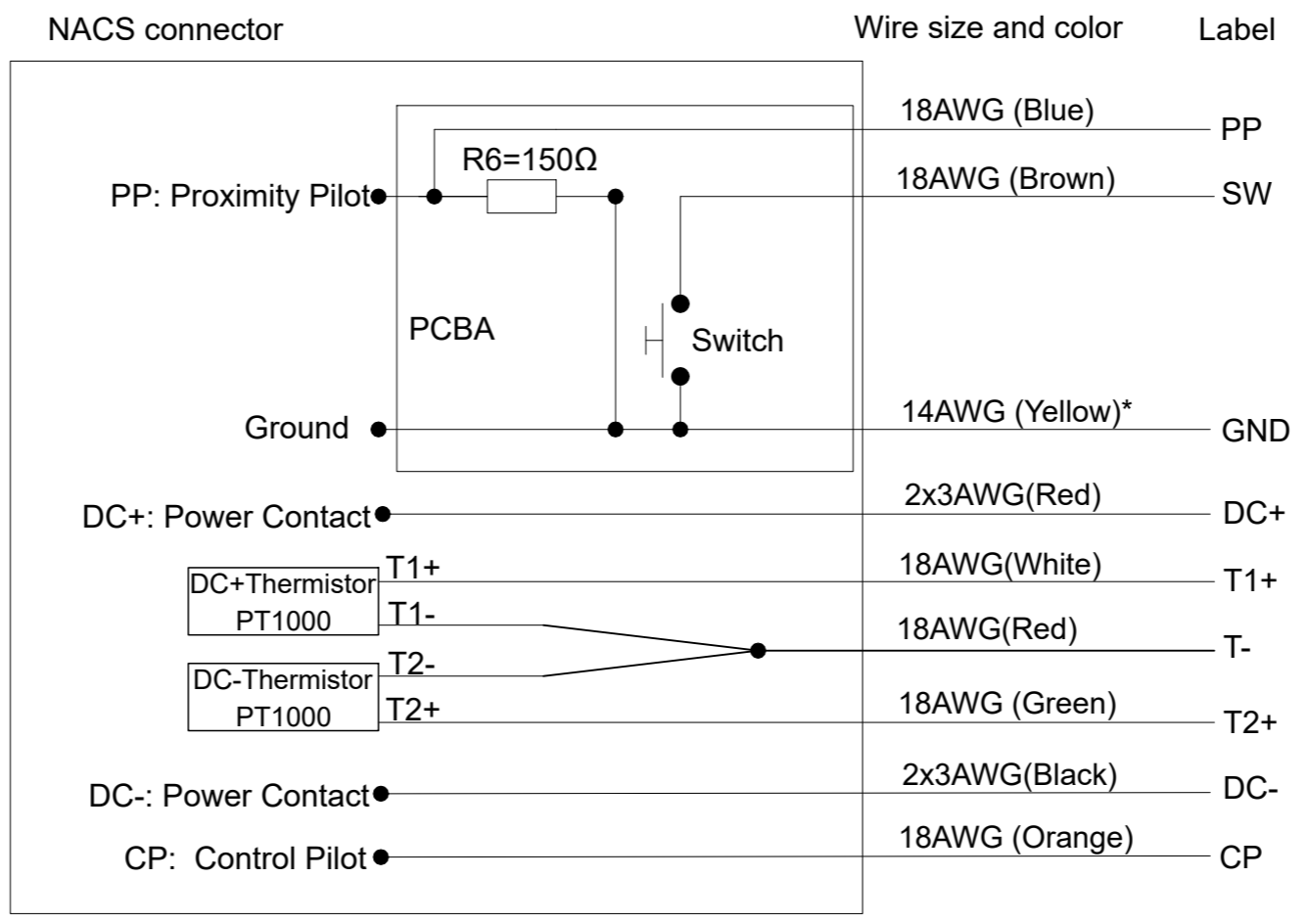

*Notes:

- Cable assembly data:
 - Rated Voltage: 1000V DC (DC+, DC-), 30V DC(CP, PP);
 - Rated Current: 250A Max (DC+, DC-) @ the max permissible temperature is 90°C
2A Max (CP, PP);
 - Insulation Resistance: 100MΩ Min, 1000V DC(DC+, DC-, GND)
100MΩ Min, 500V DC(CP, PP, Thermistor wire)
 - Withstand Voltage: 4200V / DC (DC+, DC-, GND);
700V / DC (CP, PP, Thermistor wire);

The insulation resistance and withstand voltage test cannot be performed between the wires on the PCB board; For Withstand Voltage test need to use with Direct current;

 - IP-Class: IP67 (enclosure); Type 3S (Plugged in)
 - RoHS Compliance
 - Ambient Temperature: -40°C to +50°C (+55°C max, Current reduction required, when the working temperature is beyond 90°C)
 - NACS Plug reference: C-HVCONMXXXXAXL0000X
 - Cable Minimum Bending Radius: 5xOD (Static applications); 10xOD (Dynamic applications)
 - Durability: ≥ 20,000 cycles (Replaceable)
 - Weight of Cable: app 1480g/m
 - Standard: UL2251, SAE J3400 complaint
- *Ground wire is suitable for isolated DC EV supply equipment as reference earth or function earth.

⑤	C210000080	SINGLE-WALL H.S.T: Ø5.0 BLACK	0.20	m
④	P05B000029	SINGLE-WALL H.S.T: Ø3.0 WHITE	0.14	m
③	P05B000019	SINGLE-WALL H.S.T: Ø10 WHITE	0.12	m
②	CABLE	4X3AWG+14AWG+6X18AWG BLACK OD28.7	AR	m
①	HVCON3MB250APL0000	NACS 250A PLUG BLACK NO UHF- REPLACEABLE	1	EA
ITEM	P/N	DESCRIPTION	QTY	UNIT

SIZE	DWG NO.	REV
A3	C-HVCON3MB250APLXXXX	2
SCALE	NA	SHEET 2 OF 2

C-HVCON3MB250APLXXXX

C-HVCON3MB250APLXXXX