

REV	ECN	DESCRIPTION	DATE	MODIFIED
1		FIRST-RELEASE	Mar/03/2017	
2	C4728N	MODIFIED DRAWING	Sep/04/2020	
A	C6046	UPDATED DRAWING	Jan/05/2022	
B	C6342	修改笔误	Jun/07/2022	

Amphenol PCD SZ
ORIGINAL
PDF Format
R&D

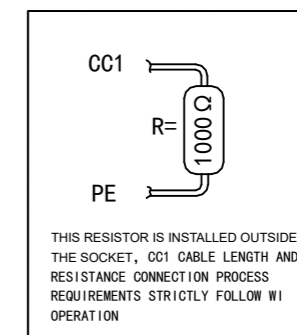

比例 4:5

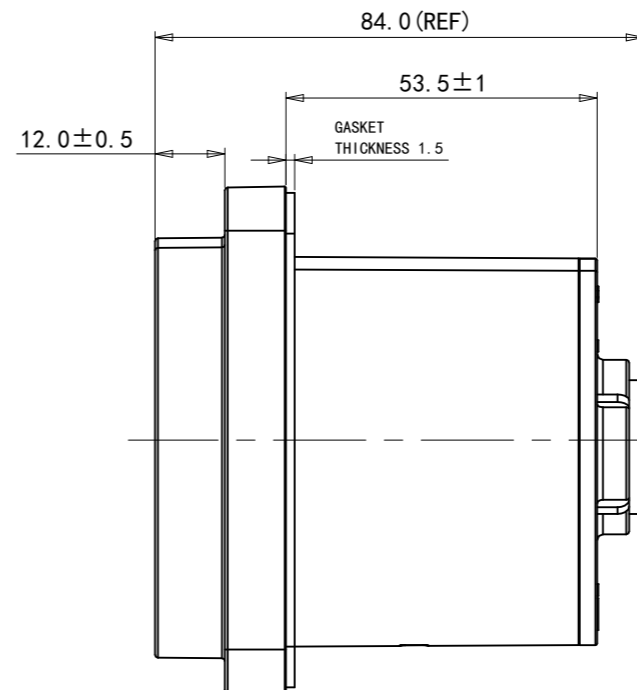
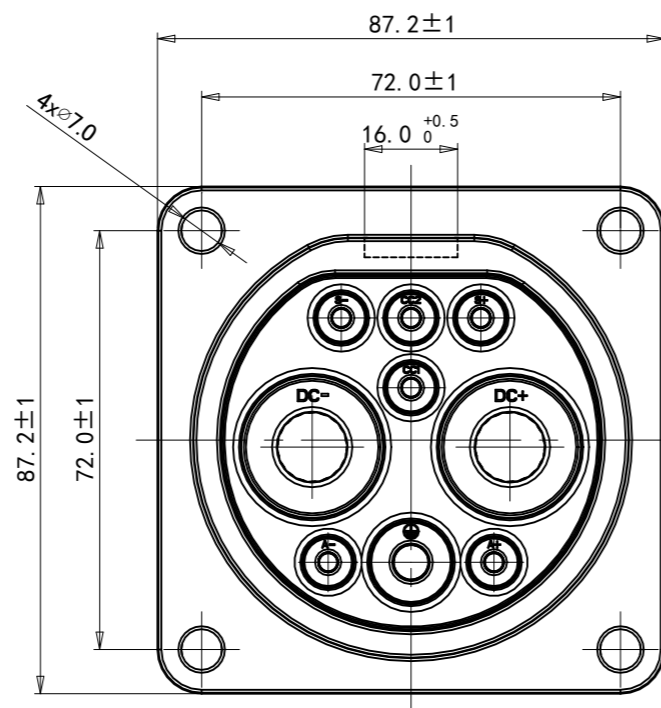

NOTES:

- TECHNOLOGY SPECIFICATION:
 - OPERATING TEMPERATURE: -30~50°C
 - OPERATING VOLTAGE&RATED CURRENT
 - DC+:750V/1000V DC 125A
 - DC-: 750V/1000V DC 125A
 - PE :GROUND/EARTH
 - S +:30V 2A
 - S - :30V 2A
 - CC1:30V 2A
 - CC2:30V 2A
 - A +:30V 20A
 - A -:30V 20A
 - Withstanding Votage:3000V DC
 - Insulation Resistance:100MΩ MIN
 - Service life:10000 CYCLES
 - IP-Class:IP54
 - AMPHENOL TEMPERATURE SENSOR P/N:C210006861
 - REFERENCE STANDARD:GB/T20234.3-2015

CABLE CONNECT METHOD

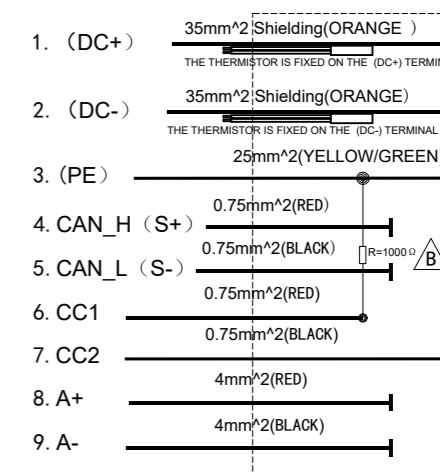

DIMENSIONS ANSI Y14.5M UNITS: MM	TOLERANCES .X ± 0.5 .XX ± 0.05 ANGLES ± 2°	PROJECTION 	Amphenol PCD Shenzhen		TITLE VEHICLE COUPLER SOCKET DC 125A		
			ENGR	Mar/03/2017	SIZE A3	DWG NO. C-HVCO01R12SF935RL0000	REV B
ORIGINAL	THIS DOCUMENT CONTAINS PROPRIETARY INFORMATION WHICH IS THE CONFIDENTIAL PROPERTY OF Amphenol PCD Shenzhen Co. Ltd Amphenol PCD Shenzhen Co. Ltd RESERVES THE RIGHT TO CLARIFY THIS DRAWING		CHKD	APPD	CODE: 58982	SCALE 4:5	SHEET 1 OF 2

C-HVCO01R12SF935RL0000

C-HVCO01R12SF935RL0000

ITEM	P/N	DESCRIPTION	QTY
1	P02B00019603	PROTECTIVE COVER ASSEMBLY	1
2	C270006861	RUBBER GASKET	1
3	G200006860	socket METAL BODY	1
4	C270006403	SEALING RING	1
5	C220006862	socket body	1
6	P02B000160	CC2 PIN ASSEMBLY	1
7	P02B00015804	DC+/DC- PIN ASSEMBLY	2
8	C270006426	16mm ² CABLE SEALING RING	2
9	C270006422	0.75mm ² CABLE SEALING RING	4
10	G220006863	HOUSING CORE	1
11	C270006310	O-RING ϕ 50.5X1.78	1
12	C220006864	BACK COVER	1
13	G210006300	SCREW ST2.9X18	4
14	C270006424	PE CABLE SEALING RING 16 ² ~25mm ²	1
15	G270006423	CABLE SEALING RING	2
16	P02B000161	6mm PIN PIN ASSEMBLY	1
17	P02B000195	A+/A- 2.5-4mm ² PIN ASSEMBLY	2
18	C210000205N	M2.5X5L SCREW	2
19	P02B000159	0.75~1.5MM ² PIN ASSEMBLY	3
20	G210006360	LR1F1K0 (1000 Ω RESISTOR)	1
21	C210006861	TR29. NTC TEMPERATURE SENSOR	2

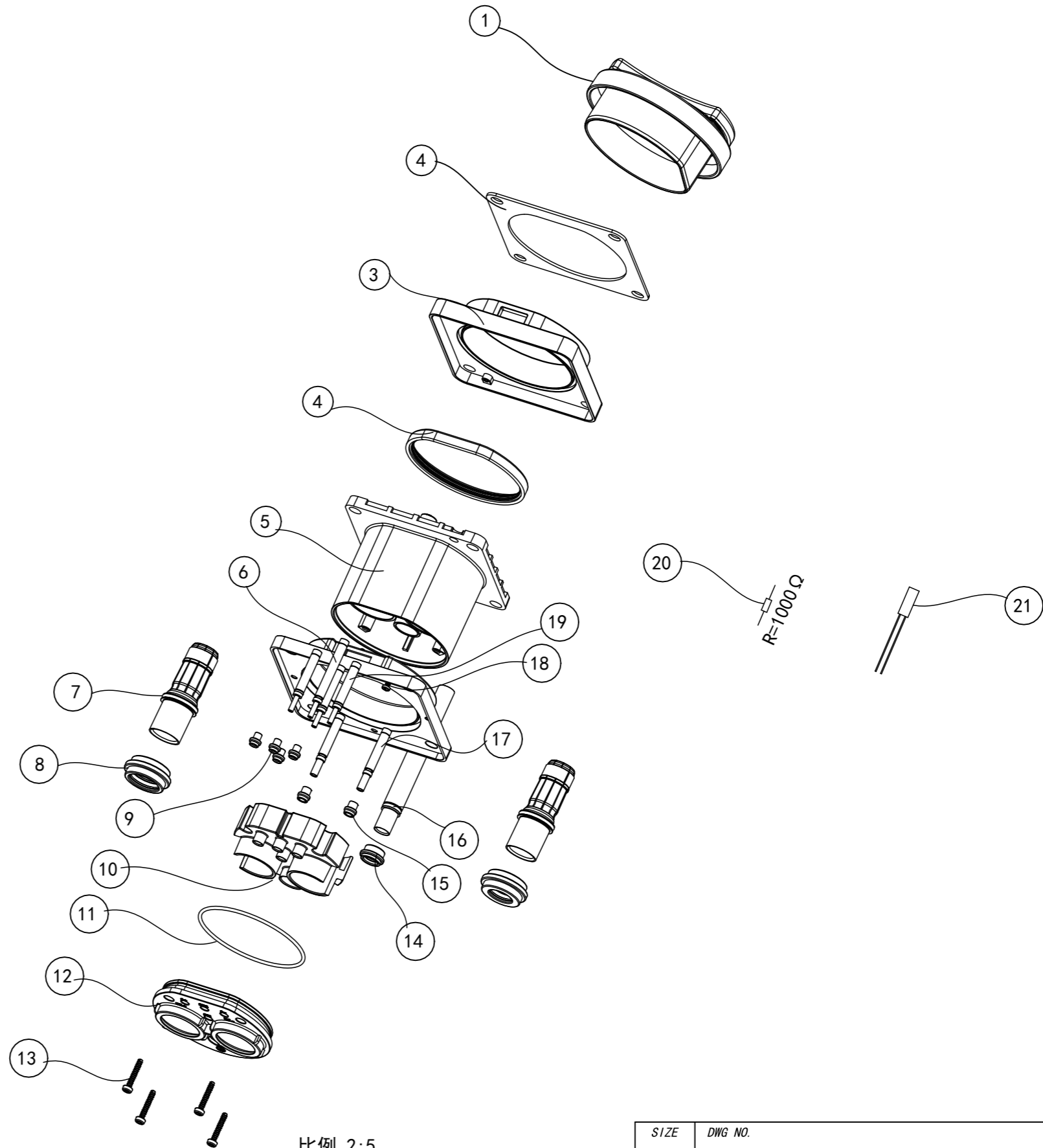

比例 2:5

SIZE	DWG NO.	REV
A3	C-HVCO01R12SF935RL0000	B
CODE:	58982	SCALE 4:5
		SHEET 2 OF 2