

HVSL635B
 ASSEMBLY INSTRUCTION

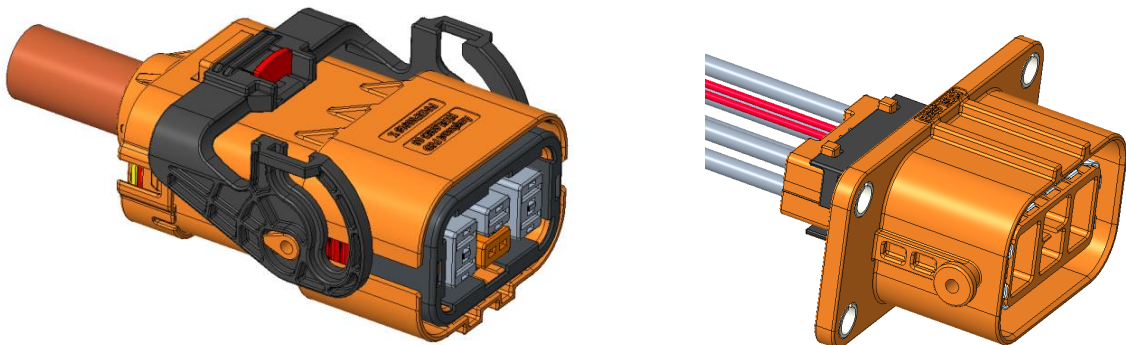

Contents

1. SCOPE.....	3
1.1. HVSL635B06 series components.	4
1.2. HVSL635B02 series components.	6
2. ASSEMBLY INSTRUCTIONS.....	7
2.1. Select the cable according to the requirements in the table below.	7
2.2. Attach the end cap, cable clamp, and sealing ring to the cable as shown below.	7
2.3. Strip the cable jacket, shield, and insulation according to size.	7
2.4. Put the shield outer ring and shield inner ring on the cable in sequence.....	8
2.5. Rivet the power terminals into shape.	8
2.6. Insert the terminal into the corresponding hole according to the cable position.....	9
2.7. Assemble shielding shell shown as below.	9
2.8. Assemble the shielded outer ring.....	10
2.9. Crimping the shield ring crimping shape and dimensions as follow, after crimping, the retention force 150 N.....	10
2.10. Insert the cable assembly into the body.....	10
2.11. Insert the seal ,cable clamp and end cap into the body. Note: According to GB9338-88 standard, the minimum bending radius of shielded cable is 6 times of the outer diameter.	11
3. ASSEMBLY INSTRUCTIONS.....	12

3.1. Select the non-shielded cable according to the requirements in the table below. 12

3.2. Strip the cable insulation layer according to the size..... 12

3.3. Rivet the power terminals into shape. 12

..... 12

3.4. Insert the cable with the riveted signal terminal and power terminal into the housing,
as shown in the figure below. 13

3.5. Install the TPA into the main body. 13

4. TEST INSTRUCTIONS.....14

4.1. 100% Withstanding Voltage and insulation resistance test:..... 14

DC 1000V, test time:60S, Insulation resistance 200MΩ..... 14

4.2. 100% Continuity Test..... 14

4.3. 100% IP67 Air tightness test. Mating with socket 14

5. APPLICATION DEVICES AND TOOLS.....15

1. SCOPE

This specification covers the requirements for the application of the HVSL635B06 and HVSL635B02 series connectors.

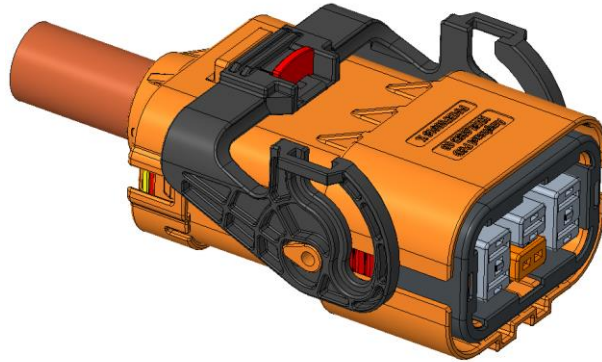

HVSL635B06 series

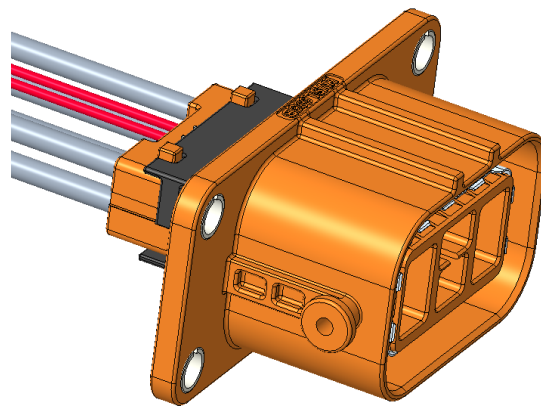

HVSL635B02 series

COMPONENTS

1.1. HVSL635B06 series components.

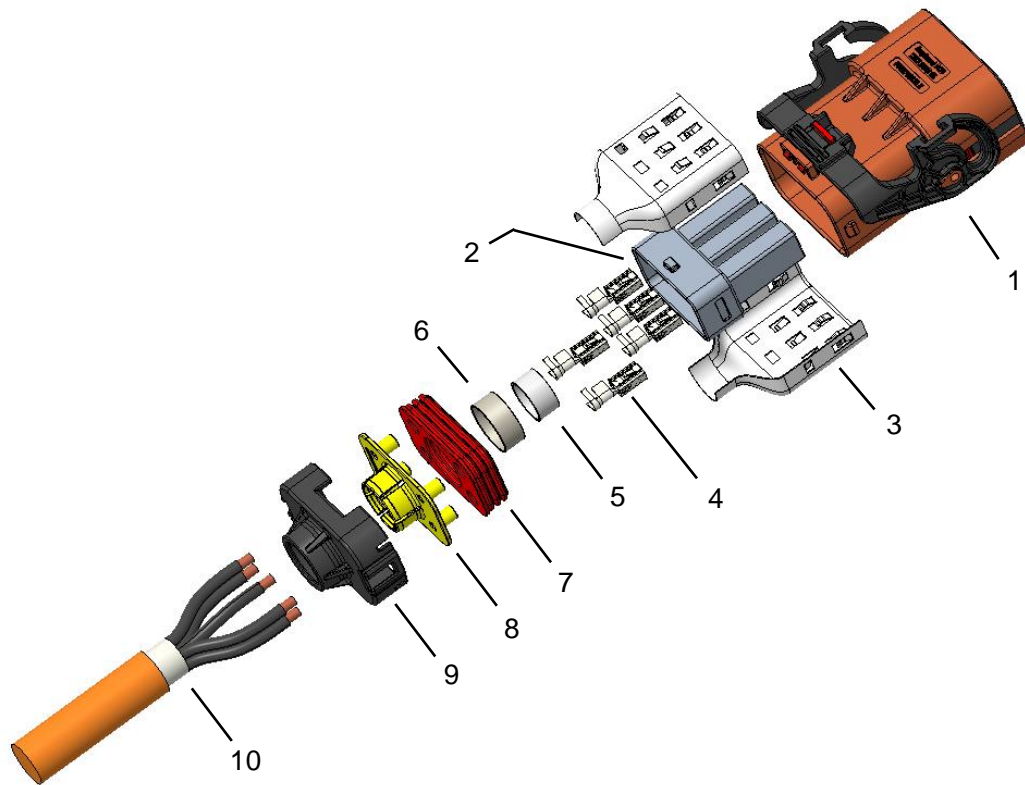

HVSL635B06 components

HVSL63506B X XX

└─ Cable OD. 01:16.3+0/-0.6 mm
└─ 0 : without HVIL / 1 : with HVIL.

HVSL635B06 series components

Item	APCD P/N	Description	QTY
1	P02B000291	Plug body.	1
2	P02B00029201	Housing assembly With HVIL.	1
	P02B00029202	Housing assembly Without HVIL.	1
3	P01BS00280	Shielding.	2
4	C310003623S	Power contact.	5
5	P01BM00388	Inner ring.	1
6	P01BM00035	Outer ring.	1
7	P01BR00477	Cable seal.	1
8	P01BP00621	Cable clamp.	1
9	P01BP00626	End cap.	1
10	--	Cable.(cable OD:16.3+0/-0.6)	-

1.2. HVSL635B02 series components.

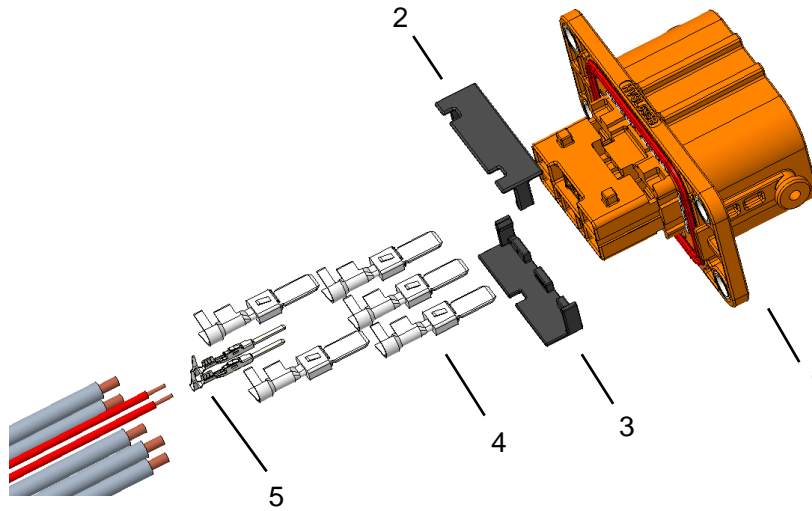

HVSL635B02 components

HVSL635B 02X XX

└─ Cable OD.
 └─ 0 : without HVIL / 1: with HVIL.

HVSL635B02 series components

Item	APCD P/N	Description	QTY
1	P02B000264	Receptacle body.	1
2	P01BP00617	TPA-1	1
3	P01BP00616	TPA-2	1
4	C310003622S	Power contact.	5
5	C310003613S	Signal contact.	2

2. ASSEMBLY INSTRUCTIONS

2.1. Select the cable according to the requirements in the table below.

Cable Specifications

CABLE SPECIFICATIONS	OD (Φ mm)	Remarks
6.0mm ²	15.7-16.3	5*6mm ²

2.2. Attach the end cap, cable clamp, and sealing ring to the cable as shown below.

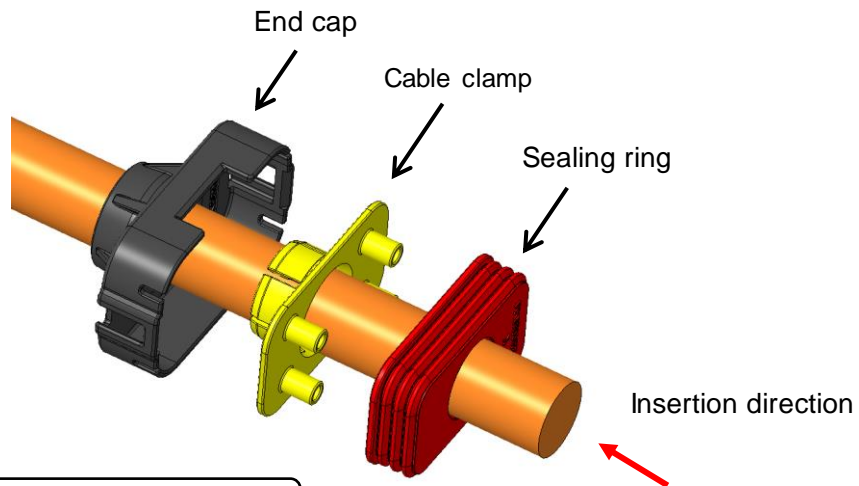

CAUTION: Ensure correct orientation!

2.3. Strip the cable jacket, shield, and insulation according to size.

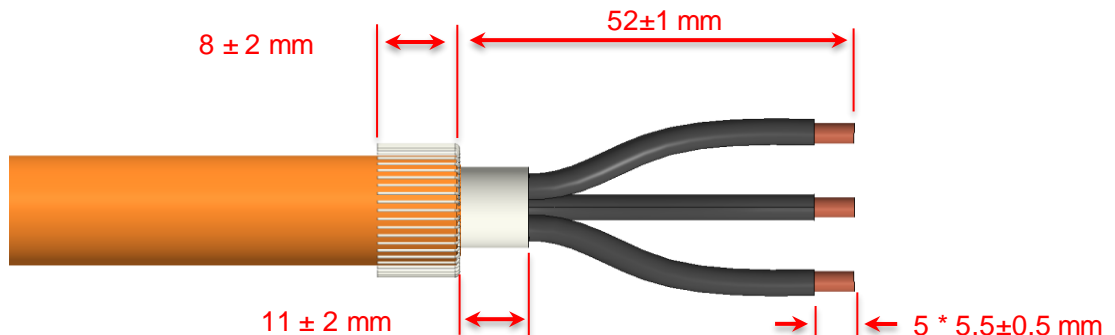

2.4. Put the shield outer ring and shield inner ring on the cable in sequence.

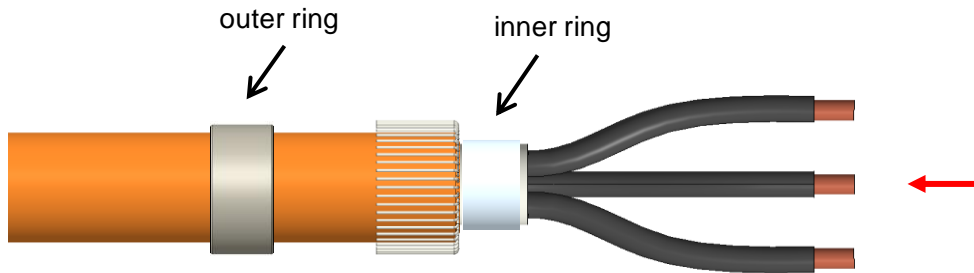

2.5. Rivet the power terminals into shape.

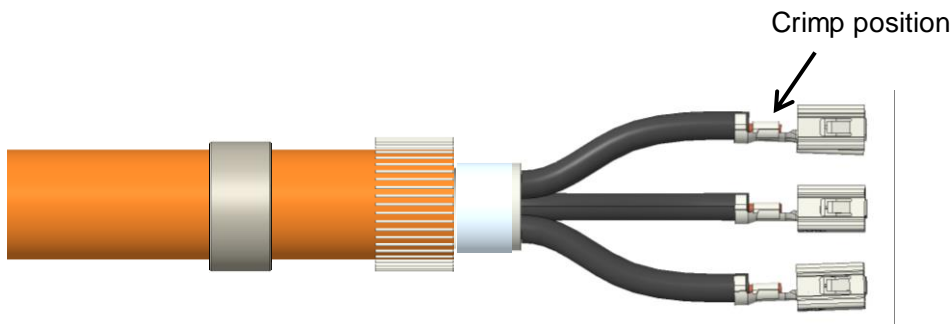

If no special requirements:

The cross-sectional acceptance criteria are in accordance with item USCAR 21-4-2020. 85% to 80% compression ratio of the section is a good place to start until there is no gap.

Retention force : 2.5mm²Above (inclusive) The tensile force meets the requirements of VW80304 6.2.11 2.5mm²below The tensile force meets the requirements of VW80302 9.1.4 table 12

Crimp resistance: The Crimp resistance meets the requirements of VW80304 5.3.1.2 table 3 Crimp resistance not mentioned in the standard shall be defined by both parties through negotiation.

2.6. Insert the terminal into the corresponding hole according to the cable position.

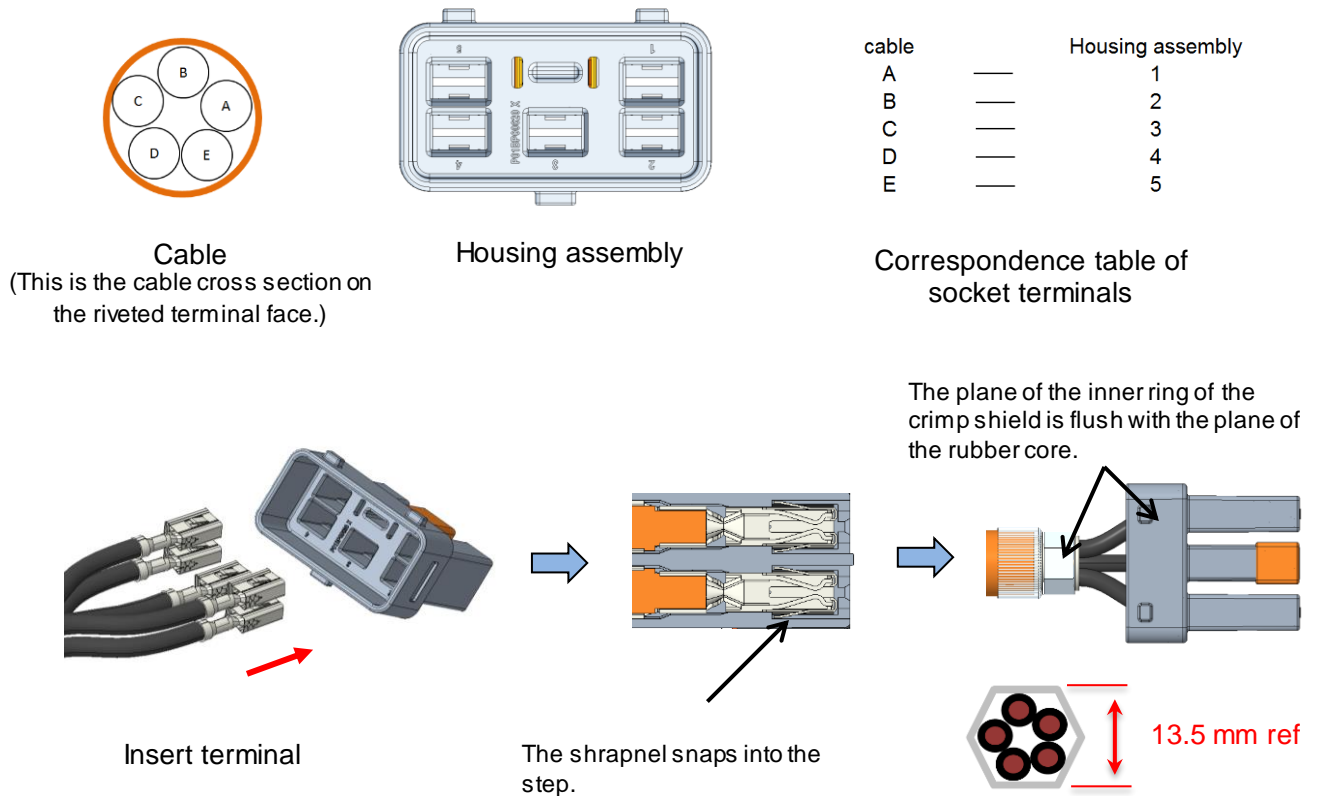

2.7. Assemble shielding shell shown as below.

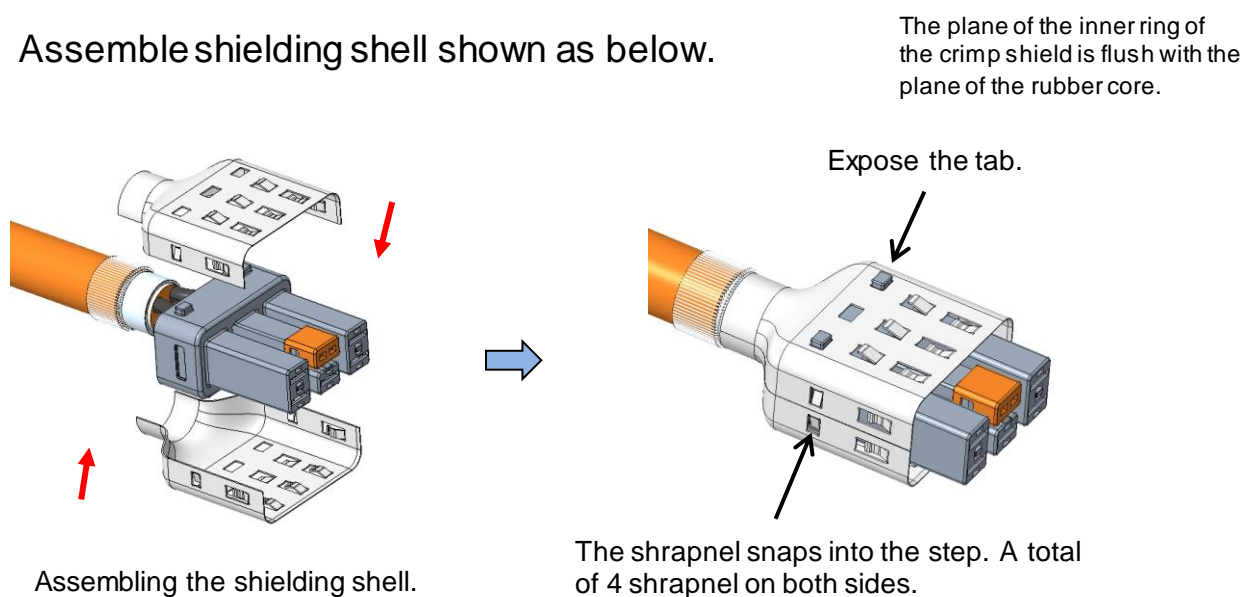

2.8. Assemble the shielded outer ring.

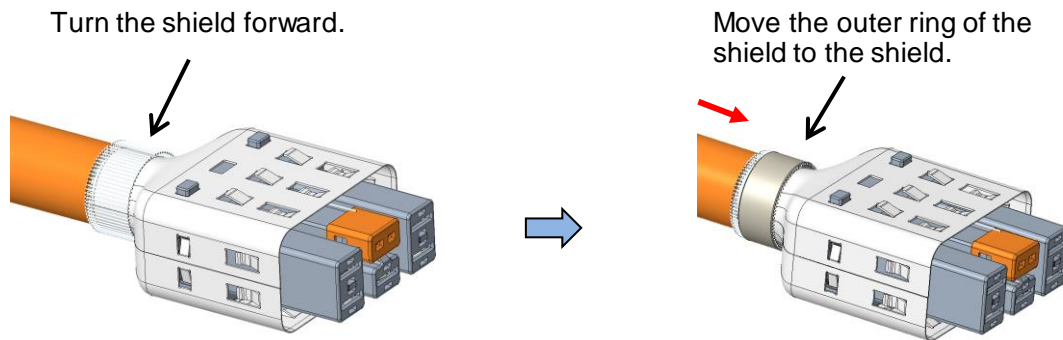

2.9. Crimping the shield ring crimping shape and dimensions as follow, after crimping, the retention force ≥ 150 N.

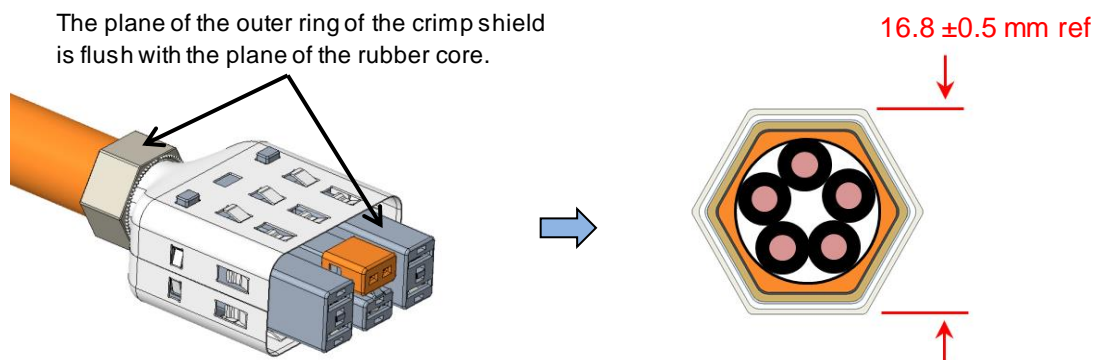

2.10. Insert the cable assembly into the body.



1 tab of the cable assembly is inserted corresponding to 1 slot inside the body.

2.11. Insert the seal ,cable clamp and end cap into the body. Note: According to GB9338-88 standard, the minimum bending radius of shielded cable is 6 times of the outer diameter.

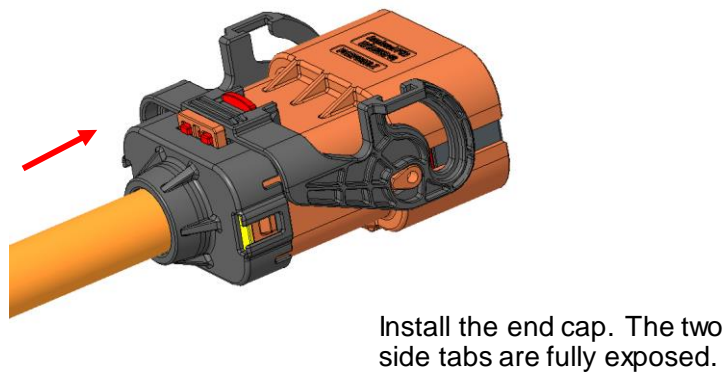
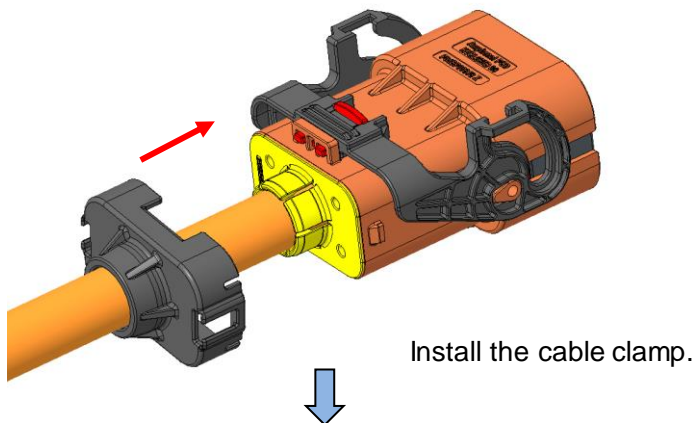
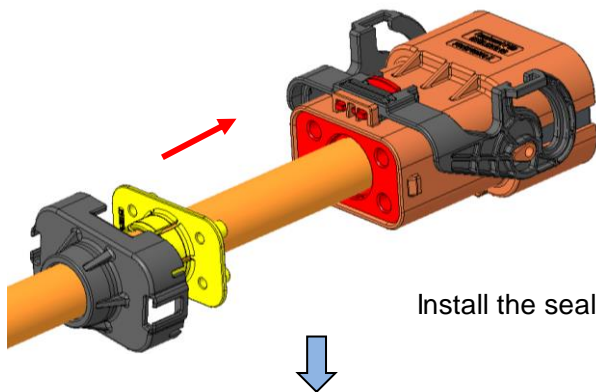

3. ASSEMBLY INSTRUCTIONS

3.1. Select the non-shielded cable according to the requirements in the table below.

Cable Specifications

CABLE SPECIFICATIONS	OD (Φ mm)	REMARK
0.5-0.75 mm ²	1.4-1.9	Signal Cable
6.0 mm ²	5.2	power Cable

3.2. Strip the cable insulation layer according to the size.



Signal cable

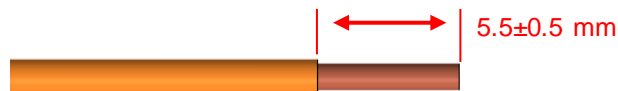

Power cable

3.3. Rivet the power terminals into shape.

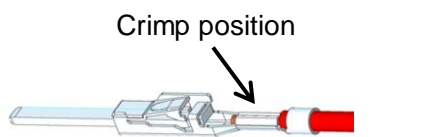

Signal cable

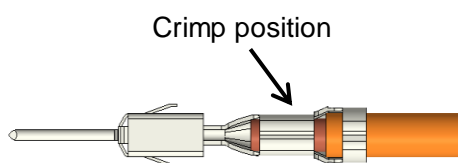

Power cable

If no special requirements:

The cross-sectional acceptance criteria are in accordance with item USCAR 21-4-2020.

85% to 80% compression ratio of the section is a good place to start until there is no gap.

Retention force : 2.5mm²Above (inclusive)

The tensile force meets the requirements of VW80304 6.2.11 2.5mm²below

The tensile force meets the requirements of VW80302 9.1.4 table 12

Crimp resistance: The Crimp resistance meets the requirements of VW80304

5.3.1.2 table 3 Crimp resistance not mentioned in the standard shall be defined by both parties through negotiation.

3.4. Insert the cable with the riveted signal terminal and power terminal into the housing, as shown in the figure below.

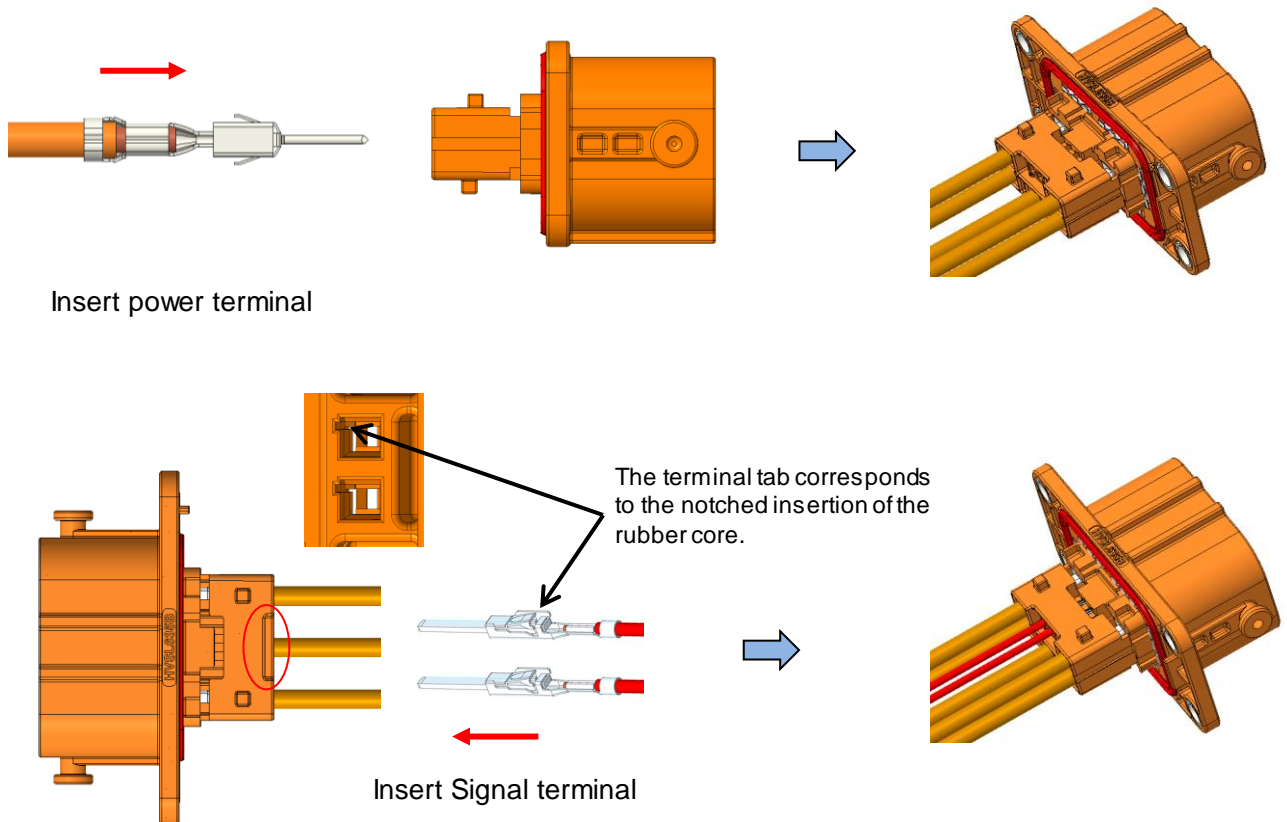

3.5. Install the TPA into the main body.

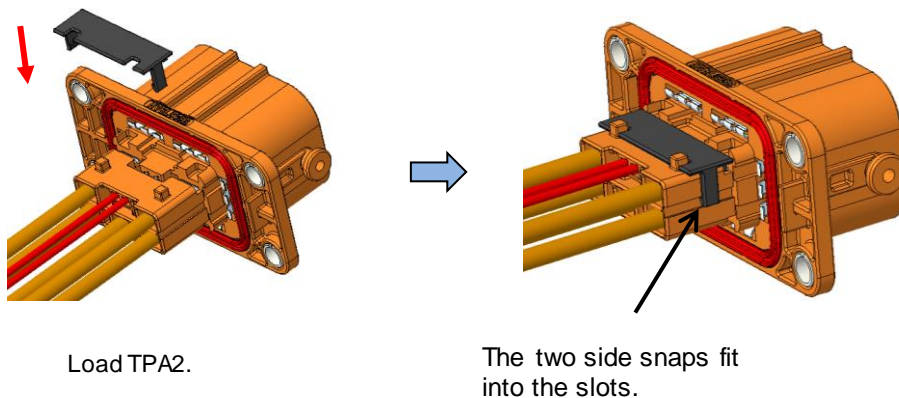

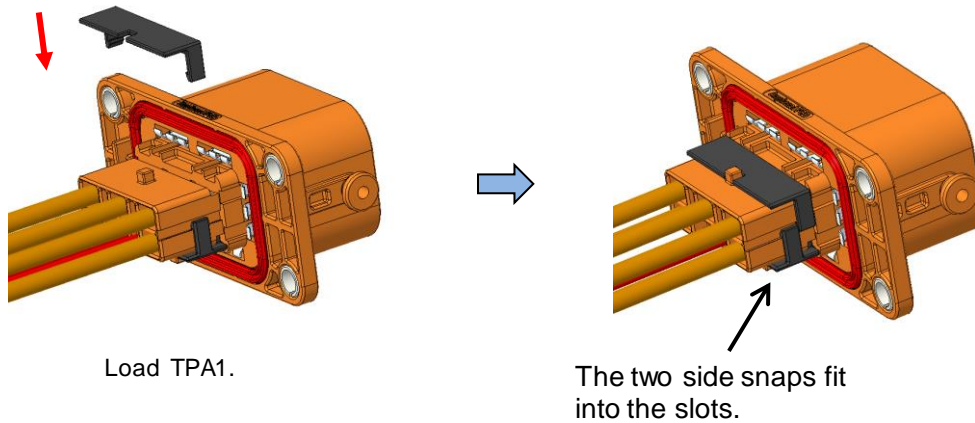

4. TEST INSTRUCTIONS

4.1. 100% Withstanding Voltage and insulation resistance test:

Test parameters: AC 2380V (Signal PIN and shield Voltage:AC690V)
test time 60S leakage current \leq 5mA.







DC 1000V, test time:60S, Insulation resistance \geq 200M Ω .

4.2. 100% Continuity Test.

4.3. 100% IP67 Air tightness test. Mating with socket

5. APPLICATION DEVICES AND TOOLS

Devices and Tools

INDEX	TOOL	FUNCTION	PICTURE	MODELE No.
1	Electrical crimping tool	Crimping shielding tube and terminals.		BZW-20T
2	Mold	Crimping shielding tube .		Width 10 mm
3	Terminal machine	The terminal mold base is mounted on the terminal machine		EV-E500
4	Terminal machine module	The die is mounted on the terminal block base		EV-M001
5	Terminal machine module blade	Riveted terminal (C310003623S)		ATD-0024
6	Terminal machine module blade	Riveted terminal (C310003613S)		ATD-0013
7	Terminal machine module blade	Riveted terminal C310003622S		ATD-0014



Amphenol PCD Shenzhen

Building 21
1st Liao Keng Industrial Zone
Shi Yan Street, Bao An District Shenzhen 518108
China

Tel.: +86 755-8173-8000
Fax: +86 755-8173-8180
Email: inquiry@amphenolpcd.com.cn
www.amphenolpcd.com.cn

Notes:

Amphenol PCD Shenzhen has made every effort to ensure that the information contained in this assembly instruction is accurate at the time of publication. Specifications or information stated in this publication are subject to change without notice.

Amphenol PCD Shenzhen reserves the right to clarify this assembly instruction.

Revision History				
Date	Rev.	Updated Content	Originator	Remark
2023-03-25	A	First release	S X .Yang	
Prepared By: S X. Yang Checked by ME: Checked by QE: <i>Wolky.yang</i> Checked by PE: <i>Celine</i> Approved by:				
Date: 2022/12/30 Date: Date : Date : 2023/3/29 Date:				