

HVSL362
ASSEMBLY INSTRUCTION



Contents

1. SCOPE.....	2
2. COMPONENTS FOR PLUG.....	3
2. ASSEMBLY INSTRUCTIONS FOR PLUG	9
3. TEST INSTRUCTRIONS.....	13
4. ASSEMBLY INSTRUCTIONS (HVSL362022X/ HVSL362022TX series)	14
5. TEST INSTRUCTRIONS FOR SOCKET.....	16
6. APPLICATION DEVICES AND TOOLS	17

1. SCOPE

This specification covers the requirements for application of the HVSL362 connector

1.1 Plug series

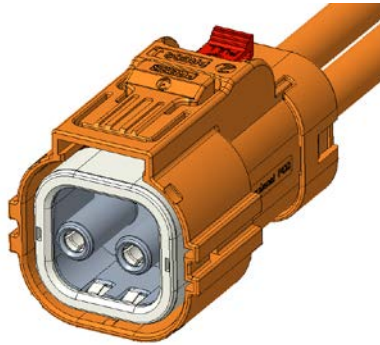

HVSL362062 series

1.2 Socket series

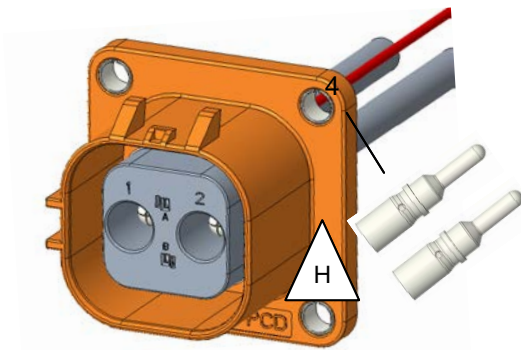

HVSL362022X series

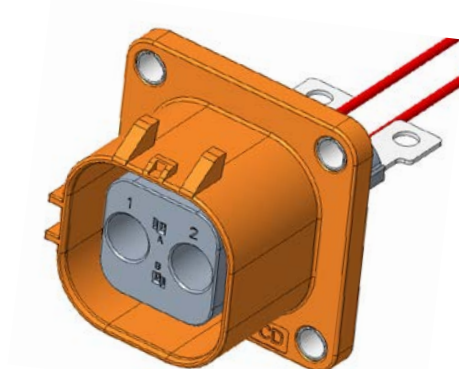

HVSL362022TX series

2. COMPONENTS FOR PLUG

2.1 HVSL362062XXXXI series components

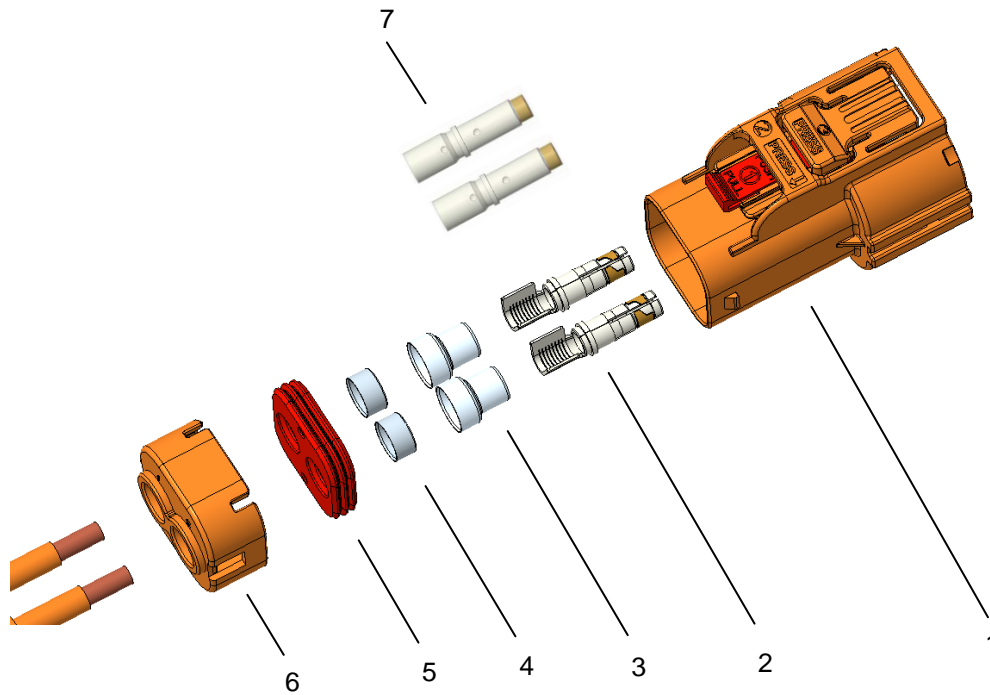

HVSL362062 X X XX I

- └─ Single shield cable
- └─ Cable specification
- └─ Interlock option: 0 no/lyes
- └─ Key option: A/B/C/D/E

HVSL362062XXXXI components

HVSL362062XXXXI material lists

Index	APCD P/N	Description	QTY
1	HVSL362062X	Key option (HVSL362062A/ HVSL362062B/ HVSL362062C/ HVSL362062D/ HVSL362062E)	1
2	C3100235021	Power terminal apply for 6.0to10.0mm ² cable (HVSL362062XX06I/ HVSL362062XX10I)	2
	P03BS00080	Power terminal apply for 16.0mm ² cable (HVSL362062XX16I)	2
3	C4200011603	Outer shielding tube, apply for 6.0mm ² cable (HVSL362062XX06I)	2
	C4200011901	Outer shielding tube, apply for 10.0mm ² cable (HVSL362062XX10I)	2
	P03BS00001	Outer shielding tube, apply for 16.0mm ² cable (HVSL362062XX16I)	2
4	C4200011202	Inner shielding tube, apply for 6.0mm ² cable (HVSL362062XX06I)	2
	C4200011902	Inner shielding tube, apply for 10.0mm ² cable (HVSL362062XX10I)	2
	P03BS00002	Inner shielding tube, apply for 16.0mm ² cable (HVSL362062XX16I)	2
5	P03BR000017	Cable seal, apply for 6.0mm ² cable (HVSL362062XX06I)	1
	C4270011607	Cable seal, apply for 10.0mm ² cable (HVSL362062XX10I)	1
	P03BR00001	Cable seal, apply for 16.0mm ² cable (HVSL362062XX16I)	1
6	P03BP00016	End cap, apply for 6.0mm ² cable (HVSL362062XX06I)	1
	C4220011906	End cap, apply for 10.0mm ² cable (HVSL362062XX10I)	1
	P03BP00002	End cap, apply for 16.0mm ² cable (HVSL362062XX16I)	1
7	P03BM00196	Machined power terminals are suitable for 16.0mm ² cable conductor specifications. (HVSL362062XX16I)	2

2.2 HVSL362062X110IS1 series components

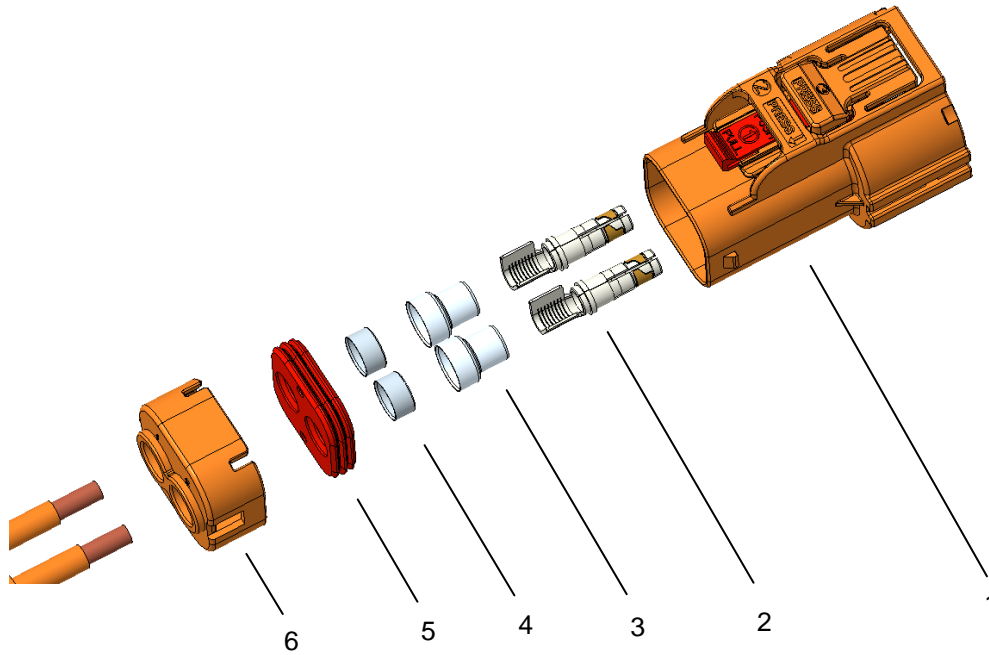

HVSL362062 X 1 10 | S1

- └ Customized P/N
- └ Single shielding cable
- └ Cable specification
- └ Interlock option :yes
- └ Key option: A/B

HVSL362062X110IS1

HVSL362062X110IS1 material lists

Index	APCD P/N	Description	QTY
1	HVSL362062X110S1	Key option (HVSL362062A110S1 / HVSL362062B110S1)	1
2	C3100235021	Power terminal apply for 10.0mm ² cable (HVSL362062A110S1/ HVSL362062B110S1)	2
3	P01BS00001	Outer shielding tube, apply for 10.0mm ² cable (HVSL362062A110S1/ HVSL362062B110S1)	2
4	P01BS00002	Inner shielding tube apply for 10.0mm ² cable (HVSL362062A110S1/ HVSL362062B110S1)	2
5	P01BR00001	Cable seal apply for 10.0mm ² cable (HVSL362062A110S1/ HVSL362062B110S1)	1
6	P01BP00002	End cap apply for 10.0mm ² cable (HVSL362062XX10I)	1

2.3 HVSL362062X116IS2 series components

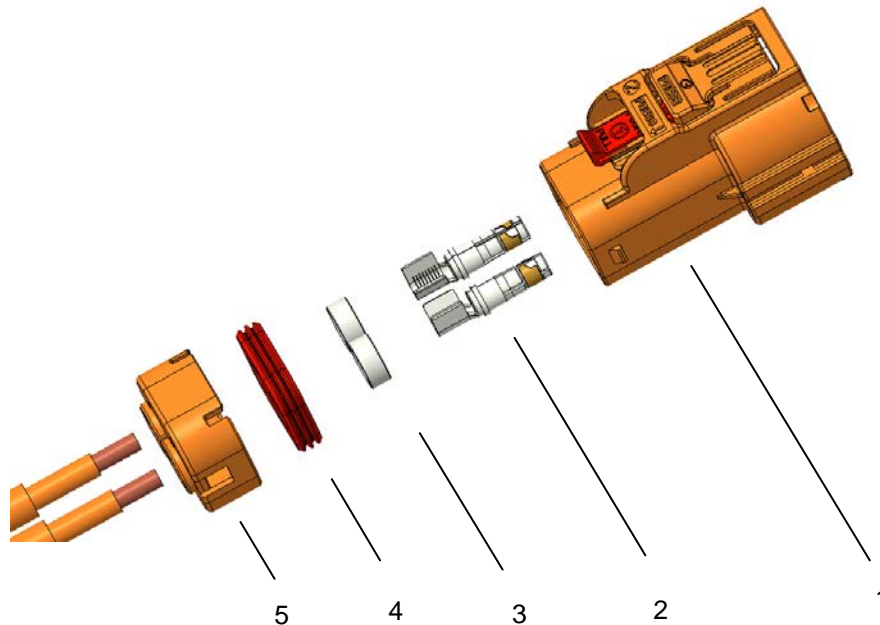

HVSL362062 X 1 16 I S2

- └─ Customized P/N
- └─ Single shielding cable
- └─ Cable specification
- └─ Interlock option: yes
- └─ Key option: A/B/C/D/E

HVSL362062X116IS2 components

HVSL362062X116IS2 material lists

Index	APCD P/N	Description	QTY
1	HVSL362062X116S2	Key option (HVSL362062A116S2 / HVSL362062B116S2 / HVSL362062C116S2 / HVSL362062D116S2 / HVSL362062E116S2)	1
2	P03BS00080	Power terminal apply for 16.0mm ² cable (HVSL362062X116S2)	2
3	P01BM00624	Shielding stop tube apply for 16.0mm ² cable (HVSL362062X116S2)	2
4	P03BR00001	Cable seal apply for 16.0mm ² cable (HVSL362062X116S2)	1
5	P01BP00150	End cap apply for 16.0mm ² cable (HVSL362062X116S2)	1

2.4 HVSL362022X series components

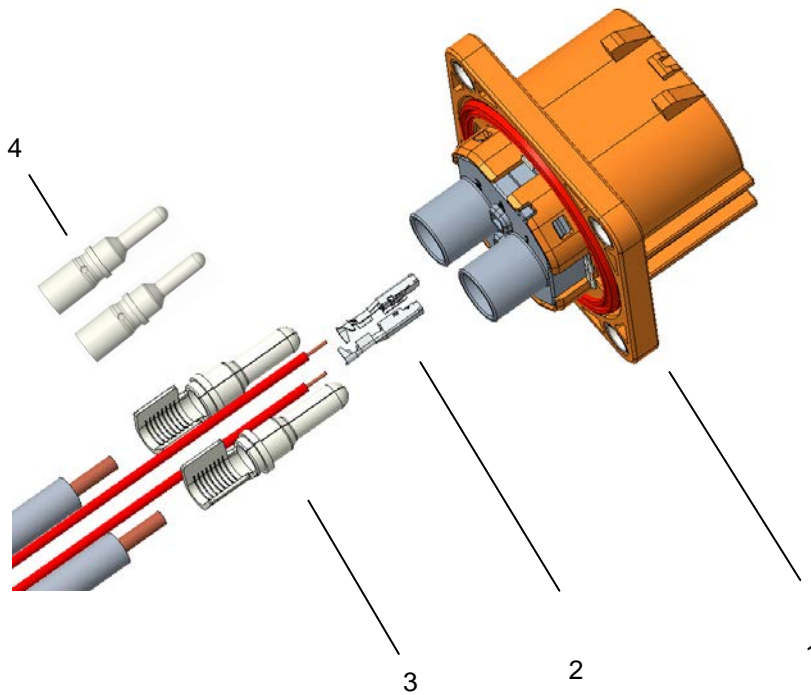

HVSL362022 X
 Key option: A/B/C/D/E

HVSL362022X components

HVSL362022X material lists

Index	APCD P/N	Description	QTY
T	HVSL362022X	Key option HVSL362022A/ HVSL362022B / HVSL362022C / HVSL362022D / HVSL362022E)	1
2	C310003614S	Signal terminal apply for 0.5mm ² cable	2
3	C3100235011	Power terminal apply for 6.0 to10.0mm ² cable	2
	P03BS00081	Power terminal apply for 16.0mm ² cable	2
4	P03BM00197	Machinetomounted power terminals for 16.0mm ² cable conductor size	2

2.5 HVSL362022TX series components

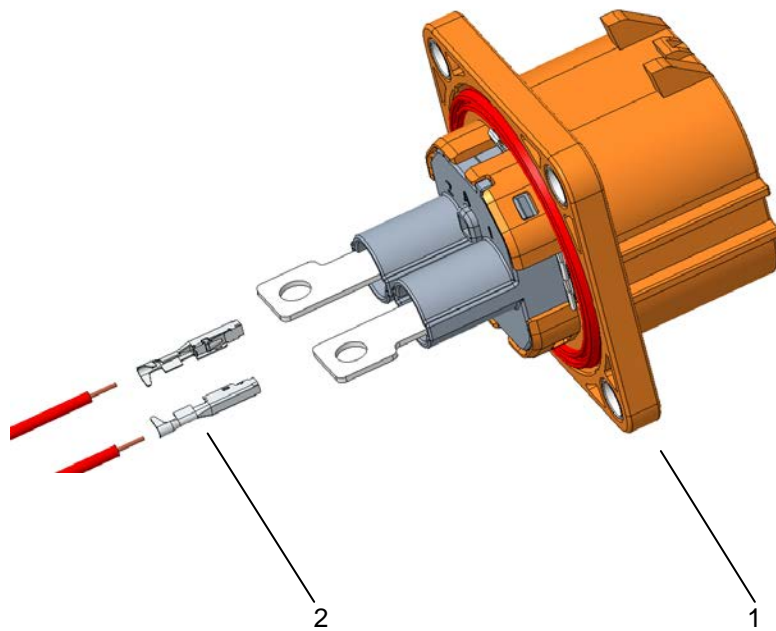

HVSL362022T X

Key option: A/B/C/D/E

HVSL362022TX components

HVSL362022TX material lists

Index	APCD P/N	Description	QTY
1	HVSL362022TX	Key option (HVSL362022TA / HVSL362022TB / HVSL362022TC / HVSL362022TD / HVSL362022T)	1
2	C310003614S	Signal terminal apply for 0.5mm ² cable	2

3. ASSEMBLY INSTRUCTIONS FOR PLUG

3.1 Select the cable according to the connector P/N.

Part number	Cable specification	OD (mm)
HVSL362062XX06I	6.0mm ²	Φ6.1 to Φ6.5
HVSL362062XX10I	10.0mm ²	Φ8.4 to Φ8.8
HVSL362062XX16I	16.0mm ²	Φ9.1 to Φ9.9
HVSL362062X110IS1	10.0mm ²	Φ9.2 to Φ9.8
HVSL362062X116IS2	16.0mm ²	Φ9.6 to Φ10.2

3.2 In order shown in figure, slide end cap and cable seal onto the cable jacket:

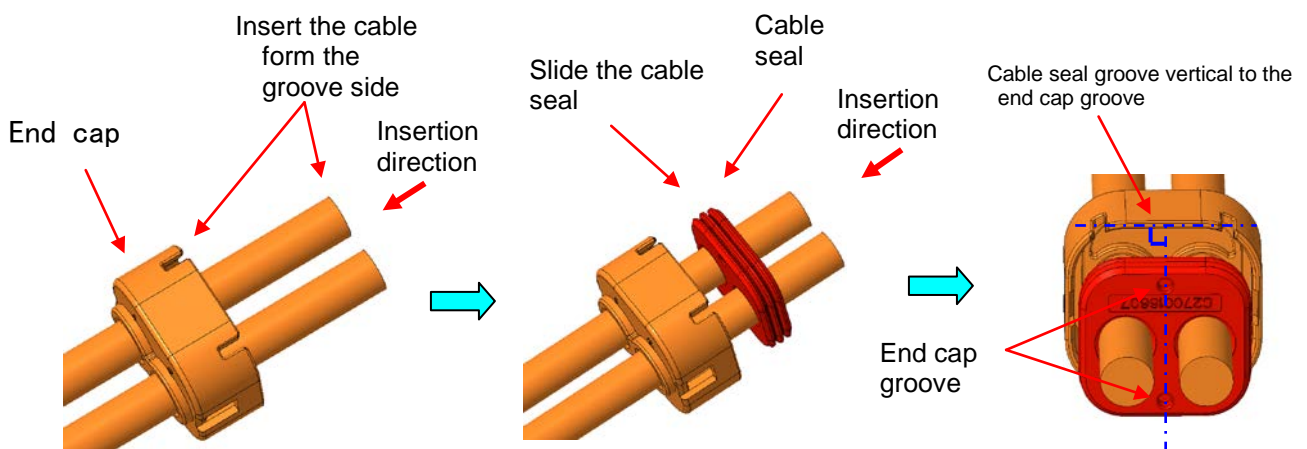

3.3 Stripping the jacket, shielding, insulation according to the below size.
Scatter the shielding and cutting the surplus shielding.

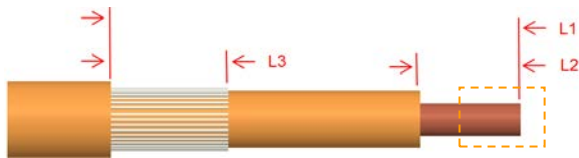

Terminal P/N	Jacket L1 (mm)	Conductor L2 (mm)	Shielding L3 (mm) ref
C3100235021 P03BS00080	27.0±0.5	10.0±0.5	7.0
P03BM00196	24.5±0.5	10.0±0.5	7.0

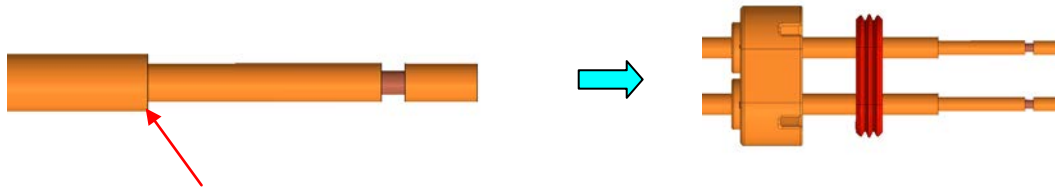

For HVSL362062X116IS2 if we select the shielding cable, must cut off the shielding braid.

3.4 First of all, slide the inner shielding tube to make the tube right surface align to the cutting surface of the cable, then raise the shielding and flip them over to wrap the inner shielding tube, finally slide the outer shielding tube on the inner shielding tube until it is stopped.

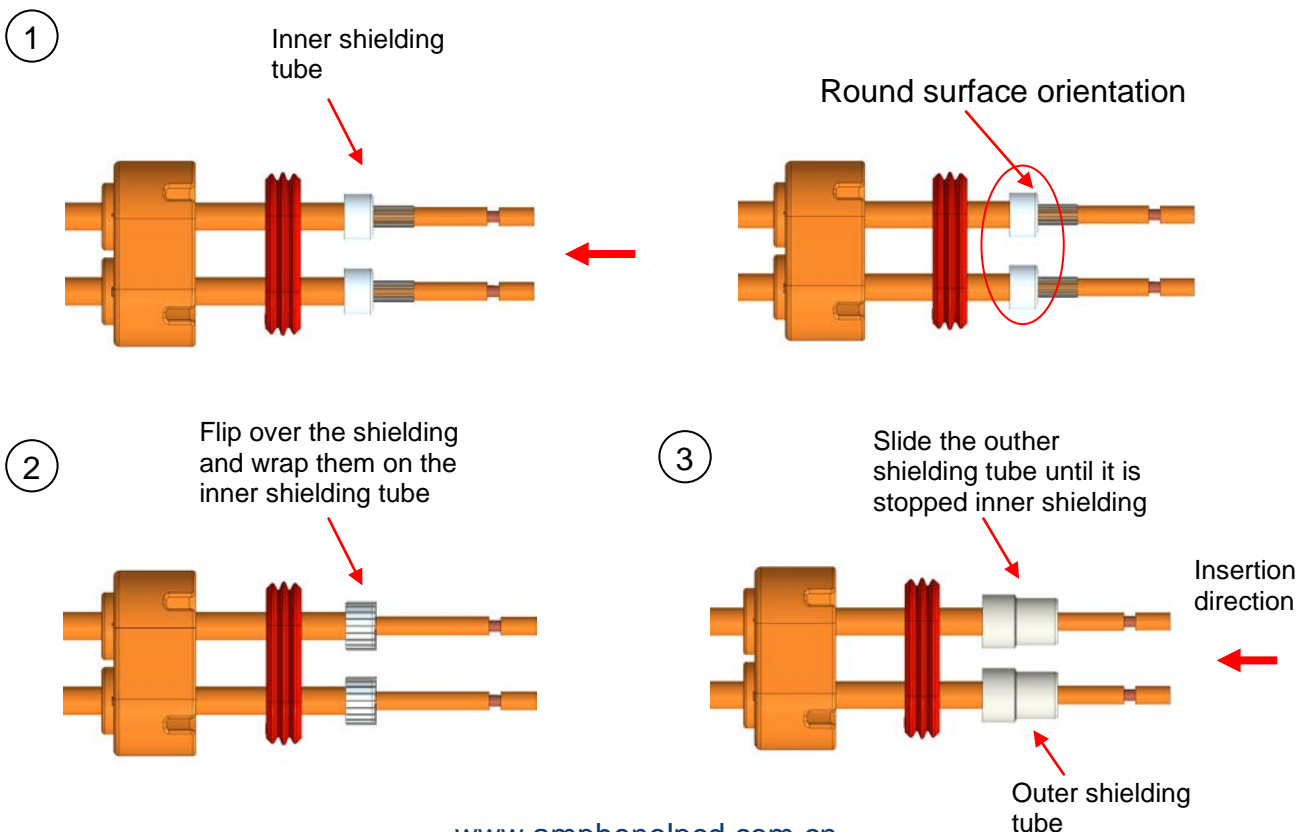

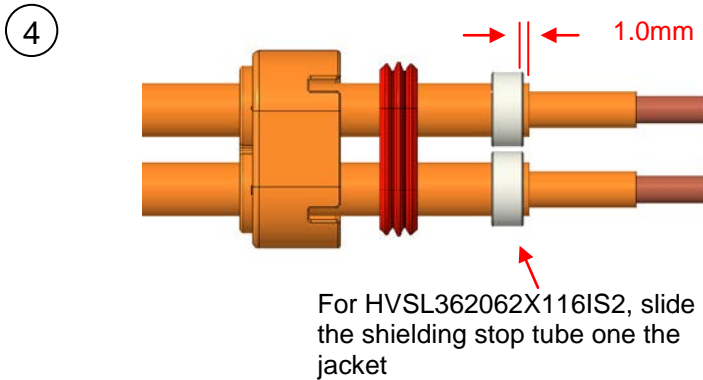

3.5 Crimp the terminals as shown in the figure below.

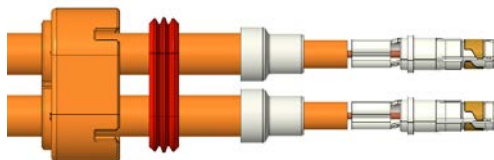

Retention force : 2.5mm² Above (inclusive) The tensile force meets the requirements of UL 486A .

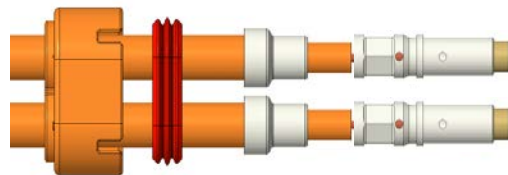

Signal terminal
P03BM00196

If no special requirements:

The crosssectional acceptance criteria are in accordance with item USCAR 21to4to2020. 85% to 80% compression ratio of the section is a good place to start until there is no gap.

3.6 Crimp the outer shielding tube with the cable, the shape and height shown as below, retention force must bigger than 150N. If the retention force can not be met, the possible reason is the cable outer diameter too small or the jacket too soft, may use the conductive filer(such as wrapping copper foil)

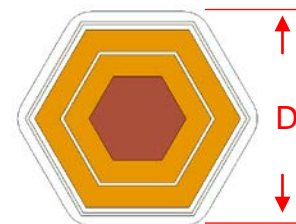
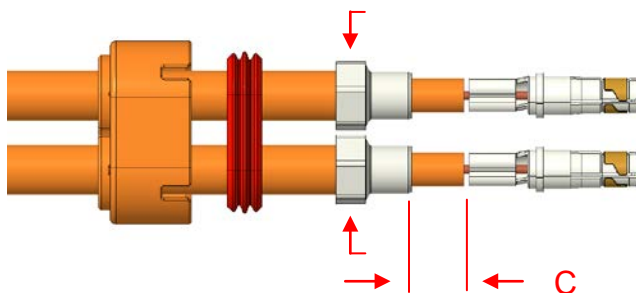

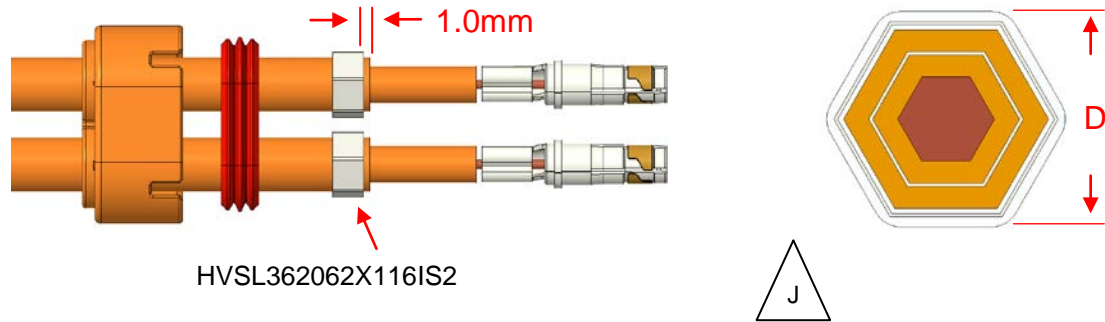

HVSL362062X116IS2

Part number	Terminal material number	Cable specification	OD (mm)	Size C (mm) Ref	Size D (mm) Ref.	Retention force
HVSL362062XX06I	C3100235021	6.0mm ²	Φ6.1 to Φ6.5	9.0±0.5	8.0±0.1	≥150N
HVSL362062XX10I	C3100235021	10.0mm ²	Φ8.4 to Φ8.8	9.0±0.5	9.4±0.1	≥150N
HVSL362062XX16I	P03BS00080	16.0mm ²	Φ9.1 to Φ9.9	9.0±0.5	10.6±0.1	≥150N
HVSL362062X110IS1	C3100235021	10.0mm ²	Φ9.2 to Φ9.8	9.0±0.5	10.2±0.1	≥150N
HVSL362062X116IS2	P03BS00080	16.0mm ²	Φ9.6 to Φ10.2	-	10.4±0.1	≥150N
HVSL362062XX16I	P03BM00196	16.0mm ²	Φ9.1 to Φ9.9	8.0+0.5/to0	10.6±0.1	≥150N

3.7 Insert the terminals into the housing, then push the cable seal into the housing shown as below picture.

①

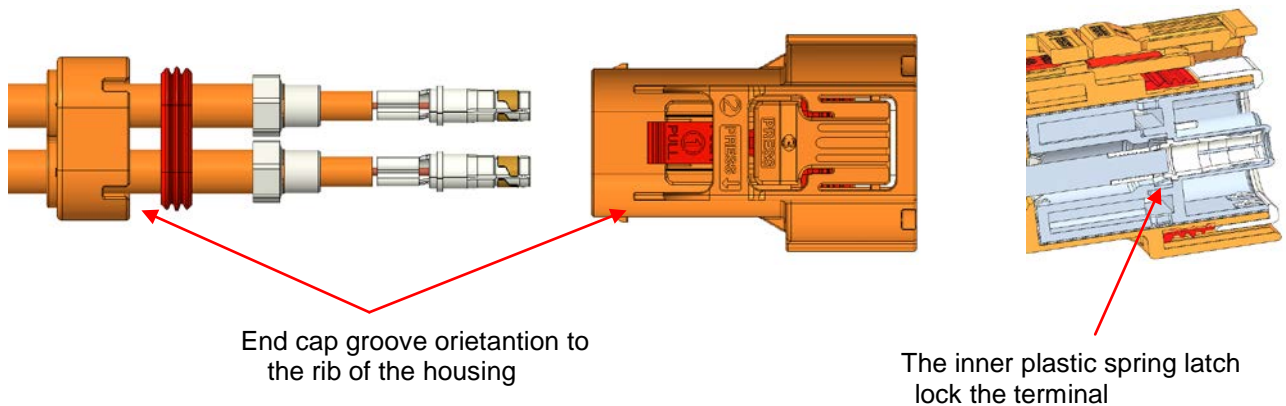

2

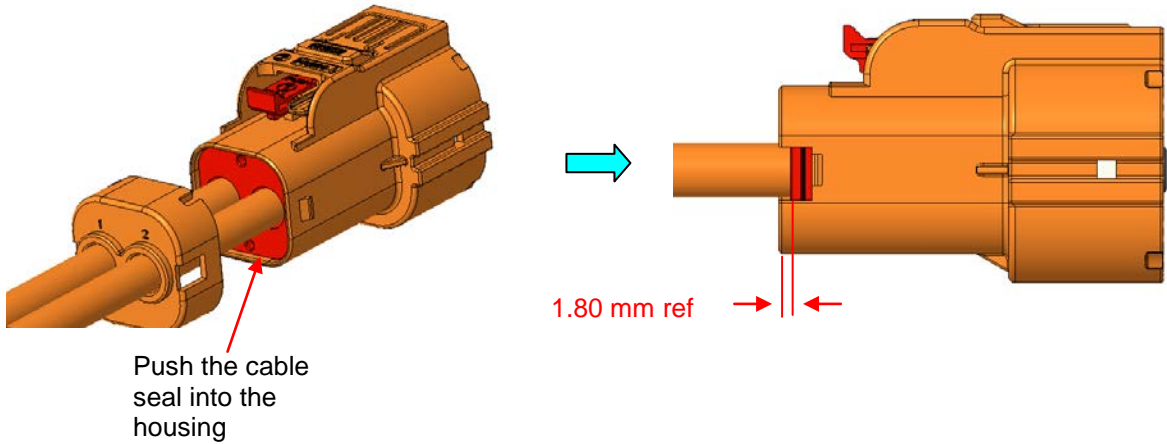

3

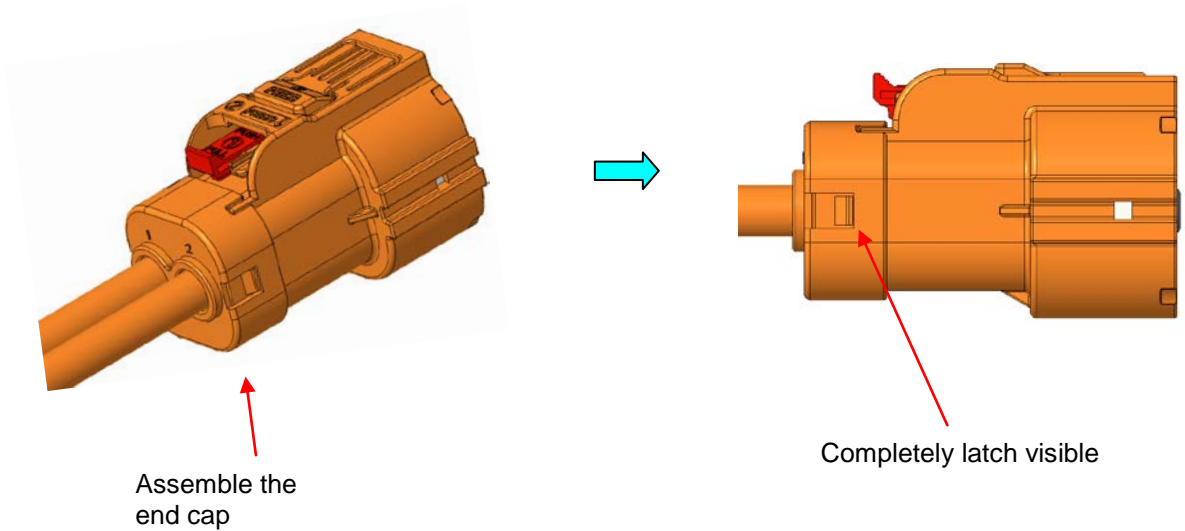

4. TEST INSTRUCTRIONS

4.1 100% Hitopot test and insulation test:

AC 3000V, 60S, leakage current \leq 5mA.

DC 500V, 10S, insulation resistance \geq 100M Ω .

4.2 100% continuity test

4.3 100% IP67 water proof testing (matched with socket)

5. ASSEMBLY INSTRUCTIONS (HVSL362022X/ HVSL362022TX series)

5.1 Select the none shielding cable

Cable specification	OD (mm)
6.0 to 16.0 mm ² (power cable)	≤ Φ7.5
0.35 to 0.5 mm ² (signal cable)	Φ1.1 to Φ1.75

5.2 Strip the power cable insulation shown as below picture.

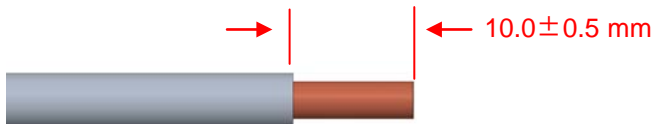

5.1 Strip the signal cable insulation shown as below picture.



5.1 Crimp the terminals as shown in the figure below.



Retention force : The tensile force meets the requirements of VW80302 (9.1.4 table 12)



Retention force : 2.5mm² Above (inclusive) The tensile force meets the requirements of UL 486A .



Signal terminal
P03BM00197
Power terminal

If no special requirements:

The cross-sectional acceptance criteria are in accordance with item USCAR 21to4to2020. 85% to 80% compression ratio of the section is a good place to start until there is no gap.

Terminal part number	Cable specification	Size E (ref)	Size F (ref)	Retention force
C310003614S	0.5mm ² Signal terminal	0.95±0.06mm	1.4±0.06mm	≥70.0N
C3100235011	6.0mm ²	3.8±0.10mm	5.8±0.10mm	≥400.5N
C3100235011	10.0mm ²	3.95±0.10mm	5.8±0.10mm	≥445.0N
P03BS00081	16.0mm ²	5.2±0.10mm	6.8±0.10mm	≥623.0N
P03BM00197	16.0mm ²	5.4±0.10mm	tototototo	≥1500N

5.2 Insert the signal terminal into the housing shown as below.

①

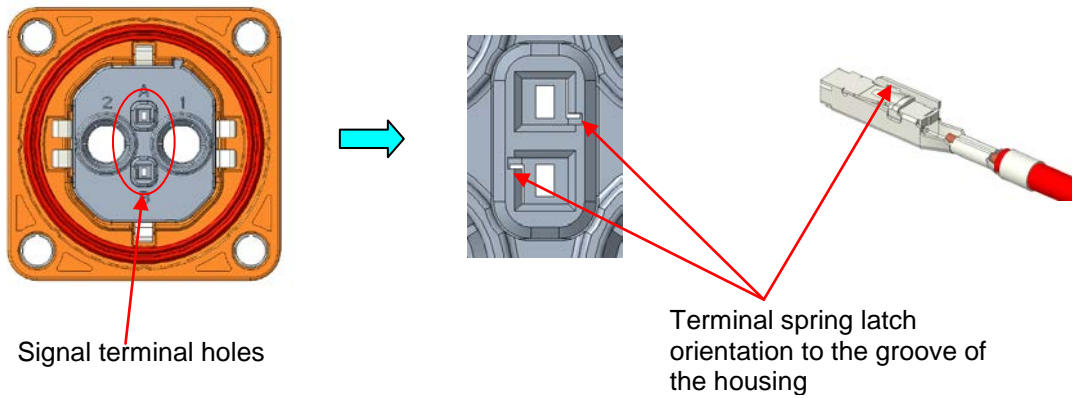

②

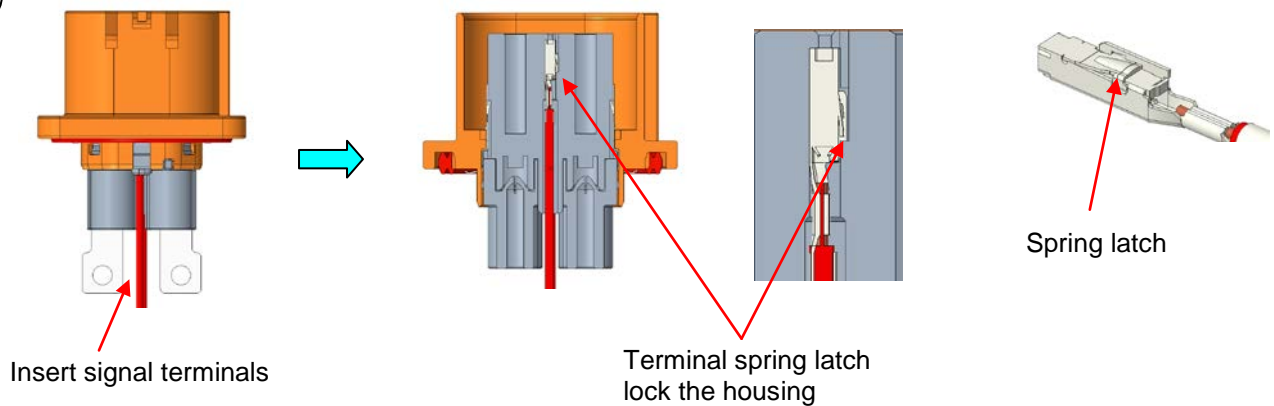

5.3 Insert the power terminals into the housing shown as below

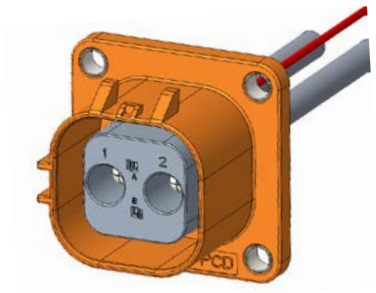
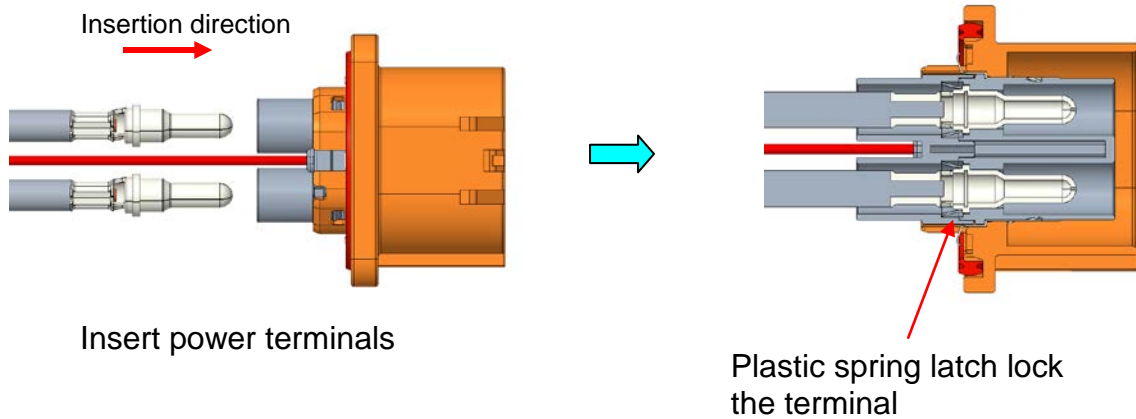

HVSL362022X series

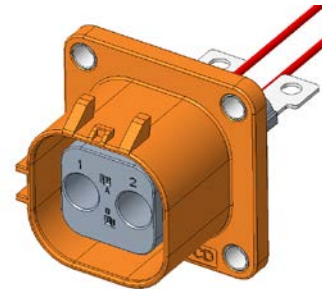

HVSL362022TX

6. TEST INSTRUCTRIONS FOR SOCKET









6.1 100% Hitopot test and insulation test:

AC 3000V (between signal PIN and shielding: AC660V), testing time: 60S,
Leake current \leq 5mA.

DC 500V, testing time: 10S, insulation resistance \geq 100M Ω .

6.2 100% continuity test

7. APPLICATION DEVICES AND TOOLS

Index	Tooling name	Fuction	Picture	Model No.
1	Electrical crimping tool	Crimping shielding tube		APSM240to10
2	Super mute crimping machine	Crimping terminal		EVtoE500
3	Applicator	Assemble on the super muter crimping machine		EVtoM002
4	Dies Terminal : C3100235021/ C3100235011,for 6to10sq cable	Assemble on the applicator for crimping termianl		ATDto0044
5	Dies Terminal : P03BS00080/ P03BS00081 for 16sq cable	Assemble on the applicator for crimping termianl		ATDto0043
6	Dies terminal:(C31003614S)	Assemble on the applicator for crimping termianl		ATDto0011
7	Extractor tool	Remove socket signal terminal		EVtoC014to00 1
8	Extractor tool	Remove socket power terminal		M81969/14to0 6



Amphenol PCD Shenzhen

Building 21
1st Liao Keng Industrial Zone
Shi Yan Street, Bao An District Shenzhen 518108
China

Tel.: +86 755to8173to8000
Fax: +86 755to8173to8180
Email: inquiry@amphenolpcd.com.cn

www.amphenolpcd.com.cn

Notes:

Amphenol PCD Shenzhen has made every effort to ensure that the information contained in this assembly instruction is accurate at the time of publication. Specifications or information stated in this publication are subject to change without notice.

Amphenol PCD Shenzhen reserves the right to clarify this assembly instruction.